

Miniature Pressure Regulator

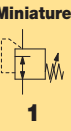

	Description		Pressure range bar	Connection thread	Device	Page
factory-set outlet pressure	Cartridge regulator		2 / 3 / 4 / 6	Cartridge	233	1.02
	without exhaust	17 x 25	2 / 3 / ... / 10	G $\frac{1}{4}$ ia	R13	1.03
	for liquids	34 x 52	1 / 2 / ... / 8	G $\frac{1}{4}$	239A	1.04
	for oxygen	34 x 52	1 / 2 / ... / 8	G $\frac{1}{4}$	239M	1.04
	for compressed air	34 x 52	1 / 2 / ... / 8	G $\frac{1}{4}$	231	1.05
	relieving		2 / 3 / ... / 8	G $\frac{1}{4}$ - G $\frac{3}{4}$	232	1.06
slim design	extremely small	19 x 40	0.2 ... 2 / 8	M5	RR-M5	1.07
	also with FKM and EPDM	18 x 65	0.2 ... 1.4 / 7	M5 / $\frac{1}{8}$ "NPT	MAR	1.08
very accurate	very leightweight		0.03 ... 0.24 / 6	$\frac{1}{8}$ "NPT	R800	1.09
	very leightweight		0.03 ... 0.24 / 6	10-32" and flange	R900	1.09
	slim design		0 ... 0.35 / 7	M5 and flange	RT	1.10
	plastic		0.1 ... 1 / 12	G $\frac{1}{8}$ and G $\frac{1}{4}$	R039-F	1.11
	modular		0.01 ... 0.7 / 7	flange	R6	1.12
	interlockable		0.01 ... 0.7 / 7	M5, G $\frac{1}{8}$, G $\frac{1}{4}$, SS	R7	1.13
	inlet pressure compensated		0.2 ... 2 / 9	flange	R342	1.14
	without constant bleed		0.2 ... 2 / 9	G $\frac{1}{8}$ and G $\frac{1}{4}$	R344	1.14
	inlet pressure compensated		0.1 ... 3 / 6	G $\frac{1}{8}$	R309	1.16
	up to 25 bar supply pressure		0.1 ... 3 / 16	G $\frac{1}{8}$ and G $\frac{1}{4}$	R310	1.16
	FDA approved		0.1 ... 1 / 12	G $\frac{1}{8}$	R037	1.17
	very accurate		0.05 ... 2 / 8	G $\frac{1}{8}$	RI	5.02
	very accurate		0.05 ... 2 / 8	G $\frac{1}{8}$ and flange	R90	5.03
standard	increased accuracy		0.1 ... 1 / 12	G $\frac{1}{8}$ and G $\frac{1}{4}$	R039	1.11
	also for water,	brass	0.1 ... 1 / 11	G $\frac{1}{8}$ and G $\frac{1}{4}$	R364	1.15
	made of aluminium		0.1 ... 1 / 11	G $\frac{1}{8}$ and G $\frac{1}{4}$	R374	1.15
	even for oxygen		0.2 ... 2.5 / 8	G $\frac{1}{8}$	R307	1.18
	even for oxygen		0 ... 0.25 / 8	flange	R308	1.19
Cartridge	upt 260 l/min		1 ... 8	G $\frac{1}{8}$ u. G $\frac{1}{4}$	RC	1.20



1

Miniature Pressure Regulator

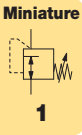

Description	Cartridge pressure regulator suitable for assembly block.		
Media	compressed air or non-corrosive gases		
Supply pressure	max. 12 bar		
Adjustment	Select the pressure regulator according to the desired outlet pressure. The outlet pressure cannot be subsequently adjusted. This safeguards against tampering.		
Relieving function	non-relieving		
Temperature range	-20 °C to 60 °C / -4 °F to 140 °F		
Material	Body: brass Elastomer: NBR/Buna-N	Piston: brass Filter: stainless steel	

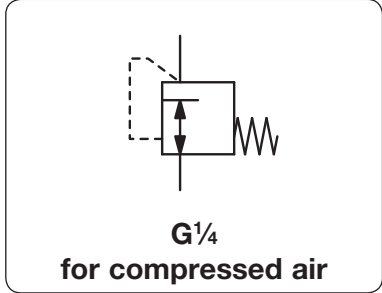

Dimensions		Flow rate	Supply pressure	Connection thread	Outlet pressure	Order number
A	A/F					
mm	mm	l/min*1	max. bar	G	bar*2	

Factory-set outlet pressure					P ₁ : max. 12 bar, non-relieving, outlet pressure accuracy *2	233
24	14	350	12	G $\frac{1}{4}$ a	2	233G0220
					3	233G0230
					4	233G0240
					6	233G0260



233

Special options, add the appropriate letter

NPT	connection thread	233GX2.0
------------	-------------------	----------

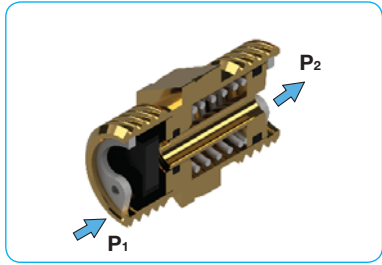

cross section

Accessories

Adapter G$\frac{1}{4}$	263F0221
--	----------



233 incl. Adapter

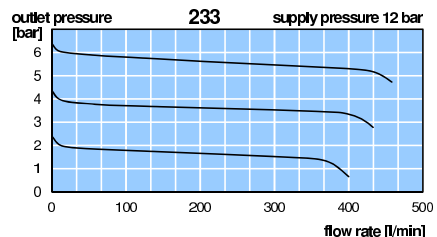
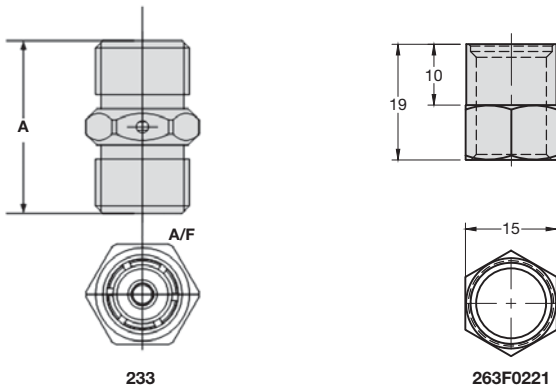

*1 P_e = 12 bar; Δp = 0.5 bar
 *2 Tolerance: 2 bar ± 0,6 bar (air, P_e = 6 bar, 10 NI/min)
 4 bar ± 0,8 bar (air, P_e = 6 bar, 10 NI/min)
 6 bar ± 1,0 bar (air, P_e = 10 bar, 10 NI/min)

In-Line Regulator with Factory-Set Outlet Pressure

R13

Description In-Line pressure regulator with factory-set outlet pressure, reducing from e.g. 10 bar to 5 bar. The regulator R13 is suited for basic pressure control only with an outlet pressure tolerance of $\pm 30\%$. The outlet pressure stated below is valid for 12 bar inlet pressure. For other inlet pressure please refer to the according item from the diagram.

Benefits

- Higher safety through lower pressure. Tools and equipment protected against pressure damages.
- Cost reduction through substantially reduced air consumption. Longer service life.
- Noise reduction for tools.

Media compressed air or non-corrosive gases

Supply pressure max. 15 bar

Adjustment Select the pressure regulator according to the desired outlet pressure. The outlet pressure cannot be subsequently adjusted. This safeguards against tampering.

Relieving function non-relieving, therefore not recommended for applications such as nailers

Temperature range 0 °C to 60 °C / 32 °F to 140 °F, for appropriately conditioned compressed air down to -30 °C / -22 °F

Material
 Body: brass
 Elastomer: NBR/Buna-N, optionally FKM

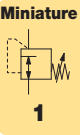
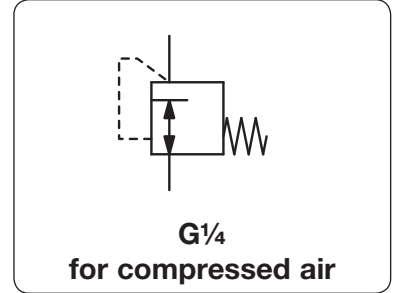

Dimensions			Flow rate	Supply pressure	Connection thread	Outlet pressure	Order number
ØA	B	SW	l/min*1	max. bar	G	bar	
mm	mm	mm					

Basic accuracy regulator						P: max. 15 bar, non-relieving, outlet pressure accuracy $\pm 30\%$, made of brass	R13
17	34	17	300	15	G1/4	2	R13-02D
						3	R13-02E
						4	R13-02F
						5	R13-02G
						6	R13-02H
						7	R13-02I
						8	R13-02K
						10	R13-02M



R13

Special options, add the appropriate letter

FKM elastomer		R13-02 . V
for oxygen	specially cleaned, with oxygen grease	R13-02 . 15



R13

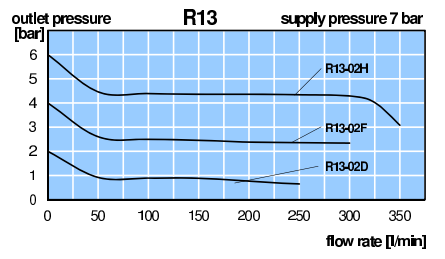
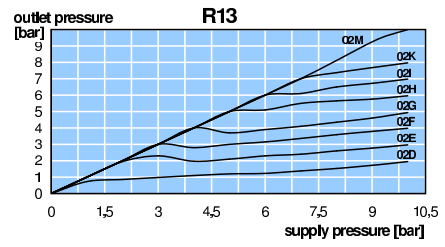
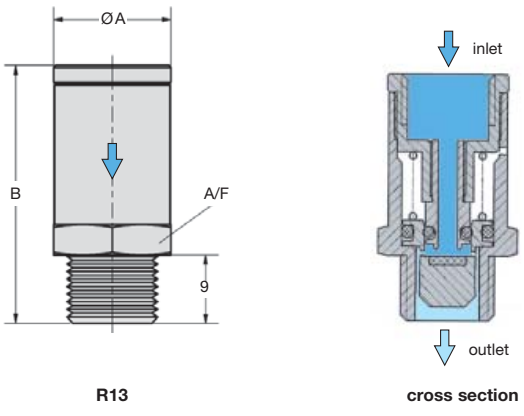

*1 at 7 bar supply pressure, 6 bar outlet pressure and 2 bar pressure drop

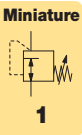

General information In-Line pressure regulator with factory-set outlet pressure, reducing from e.g. 10 bar to 5 bar. The regulator is suited for basic pressure control only with an outlet pressure tolerance of approx. $\pm 10\%^{*2}$. The outlet pressure cannot be subsequently adjusted. This safeguards against tampering.

Description 239A: regulator for liquids, compressed air and non-corrosive gases
239M: medical industry and pharmaceuticals

Application water, hydraulic and sprinkler systems, cooler, cleaning systems

Supply pressure max. 10 bar for liquids or oxygen
max. 18 bar for compressed air and non-corrosive gases

Temperature range 0 °C to 60 °C / 32 °F to 140 °F

Material Body: nickel-plated brass
Inner parts: brass
Elastomer: NBR/Buna-N for 239A, FKM for 239M

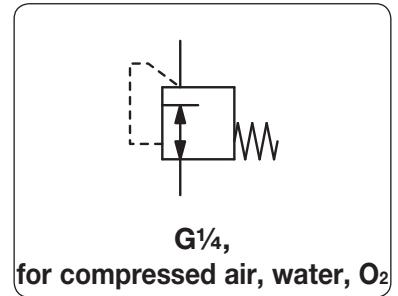

Dimensions			Flow rate		Supply pressure	Connection thread	Outlet pressure	Order number
ØA	B	A/F	water	air	max. bar	G	bar*2	
mm	mm	mm	l/min*1					

Regulator for compr. air / water made of brass, P_i: max. 18 bar / 10 bar, NBR/Buna-N, outlet pressure accuracy *2 **239A**

ØA	B	A/F	water	air	Supply pressure	Connection thread	Outlet pressure	Order number
34	52	17	3	400	18/10	G1/4	1	239A0210
			4	600			2	239A0220
			4	700			3	239A0230
			4	700			4	239A0240
			4	700			5	239A0250
			4	800			6	239A0260
			4	800			7	239A0270
			4	800			8	239A0280



Regulator for oxygen made of brass, P_i: max. 10 bar, FKM, outlet pressure accuracy *2 **239M**

ØA	B	A/F	water	air	Supply pressure	Connection thread	Outlet pressure	Order number
34	52	17	-	400	10	G1/4	1	239M0210
			-	600			2	239M0220
			-	700			3	239M0230
			-	700			4	239M0240
			-	700			5	239M0250
			-	800			6	239M0260
			-	800			7	239M0270
			-	800			8	239M0280

Special options, add the appropriate letter

NPT connection thread 239A1 . . .

deviant pressure range indicate on order 239 . . . 2XX

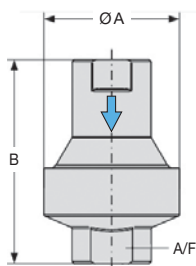

239A / 239M

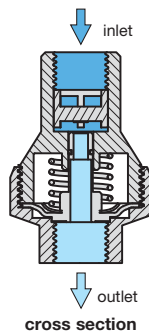

*1 P_i = 10 bar; Δp = 0.8 bar

*2 Tolerance: < 4 bar ± 0.3 bar (air, P_e = 6 bar, 10 NI/min)
≥ 4 bar ± 10% (air, P_e = 10 bar, 10 NI/min)

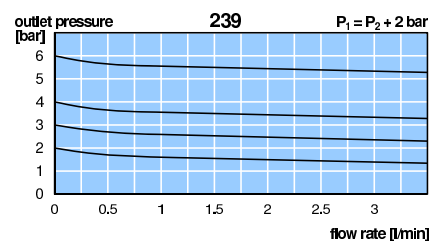
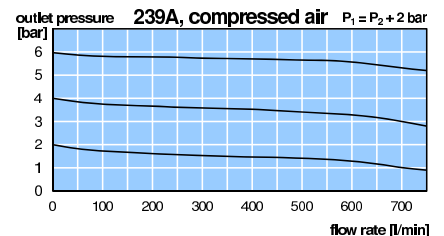

Description	In-Line pressure regulator with factory-set outlet pressure, reducing from e.g. 15 bar to 5 bar. The regulator is suited for basic pressure control only with an outlet pressure tolerance of approx. $\pm 10\%$ ² . Non-relieving function, therefore not recommended for applications such as nailers
Benefits	<ul style="list-style-type: none"> • Higher safety through lower pressure. Tools and equipment protected against pressure damages • Cost reduction through substantially reduced air consumption • Noise reducing for tools
Media	compressed air, non-corrosive gases
Supply pressure	max. 18 bar
Adjustment	Select the pressure regulator according to the desired outlet pressure. The outlet pressure cannot be subsequently adjusted. This safeguards against tampering.
Relieving function	non-relieving
Temperature range	0 °C to 60 °C / 32 °F to 140 °F
Material	Body: zinc Elastomer: NBR/Buna-N

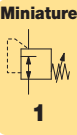
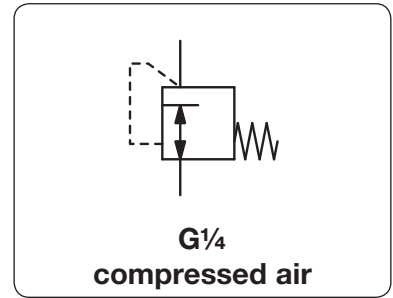

Dimensions			Flow rate	Supply pressure	Connection thread	Outlet pressure	Order number
ØA	B	A/F	l/min*1	max. bar	G	bar*2	

Regulator for air „SaveAir®“				P: max. 18 bar, non-relieving, accuracy *2, made of zinc		231	
34	52	17	400	18	G1/4	1	231A0210
			600			2	231A0220
			700			3	231A0230
			700			4	231A0240
			700			5	231A0250
			800			6	231A0260
			800			7	231A0270
			800			8	231A0280



231

Special options, add the appropriate letter

NPT	connection thread	231A 12 . .
deviant pressure range	indicate on order	231A . 2XX

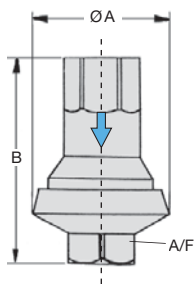

231

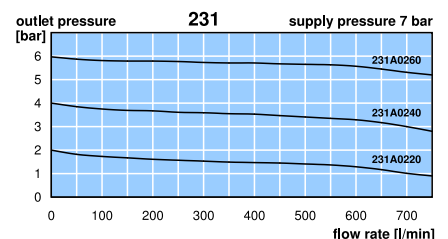
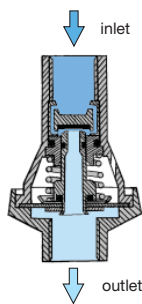

*1 $P_o = 12 \text{ bar}$; $\Delta p = 0.5 \text{ bar}$

*2 Tolerance: $< 4 \text{ bar} \pm 0.3 \text{ bar}$ (air, $P_o = 6 \text{ bar}$, 10 NI/min)
 $\geq 4 \text{ bar} \pm 10\%$ (air, $P_o = 10 \text{ bar}$, 10 NI/min)



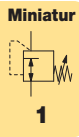

Description In-Line pressure regulator with factory-set outlet pressure, reducing from e.g. 15 bar to 6 bar. With an outlet pressure tolerance of only ±10% ² it is especially suitable for nailing machines.

Benefits

- Higher safety through lower pressure. Tools and equipment protected against pressure damages.
- Cost reduction through substantially reduced air consumption. Longer service life.
- Noise reduction for tools.

Media compressed air or non-corrosive gases

Supply pressure max. 25 bar

Adjustment Select the pressure regulator according to the desired outlet pressure. The outlet pressure cannot be subsequently adjusted. This safeguards against tampering.

Relieving function relieving at removal of supply pressure

Temperature range 0 °C to 80 °C / 32 °F to 176 °F

Material Body: aluminium
Elastomer: NBR/Buna-N

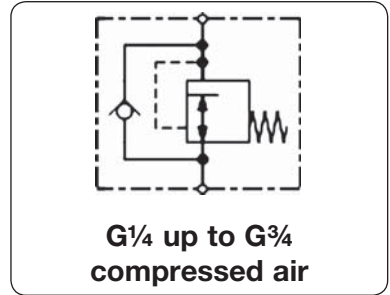

Dimensions				Flow rate	Supply pressure	Connection thread	Outlet pressure	Order number
ØA	B	A/F 1	A/F 2					
mm	mm	mm	mm	l/min*1	max. bar	G	bar*2	

Regulator with relieving function				P: max. 25 bar, accuracy*2, aluminium		232		
19	69	16	19	500	25	G ¹ / ₄ ia	2	232F0220
				550			3	232F0230
				600			4	232F0240
				650			5	232F0250
				700			6	232F0260
				750			7	232F0270
				800			8	232F0280
				19			59	16
550	3	232A0230						
600	4	232A0240						
650	5	232A0250						
700	6	232A0260						
750	7	232A0270						
800	8	232A0280						
25	63	22	25		1400	25		
				1600	3		232A0330	
				1800	4		232A0340	
				2000	5		232A0350	
				2200	6		232A0360	
				2400	7		232A0370	
				2600	8		232A0380	
				30	68		27	30
1600	3	232A0430						
1800	4	232A0440						
2000	5	232A0450						
2200	6	232A0460						
2400	7	232A0470						
2600	8	232A0480						
40	102	34	40			2500		
				3200	4	232A0540		
				3900	6	232A0560		
				4600	8	232A0580		



Special options, add the appropriate letter

NPT connection thread 232. 1 . . .
deviant pressure range indicate on order 232. . . X X

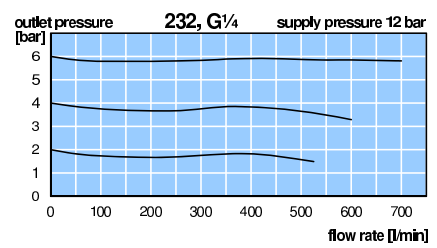
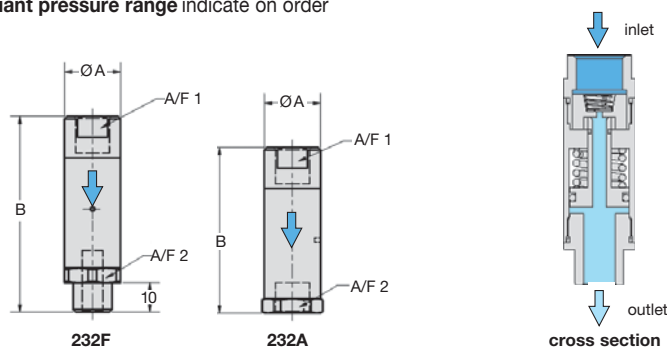

*1 P_s = 12 bar; Δp = 0.5 bar
 *2 Tolerance: < 4 bar ± 0.3 bar (air, P_s = 6 bar, 10 Nl/min)
 ≥ 4 bar ± 10% (air, P_s = 10 bar, 10 Nl/min)

Micro Pressure Regulator

RR-M5

Description	Highly compact piston-operated regulator, suitable for panel mounting and basic pressure regulation.
Media	compressed air, non-corrosive gases or liquids
Supply pressure	max. 6 bar at 0.2 ... 2 bar pressure range, max. 10 bar at 1 ... 8 bar pressure range
Adjustment	by knurled-head screw with locknut
Relieving function	relieving for air, non-relieving for water
Gauge port	not available
Mounting position	any
Temperature range	0 °C to 60 °C / 32 °F to 140 °F, for appropriately conditioned compressed air down to -30 °C / -22 °F
Material	Body: nickel-plated brass Elastomer: NBR/Buna-N Inner valve: stainless steel and brass

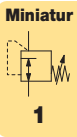
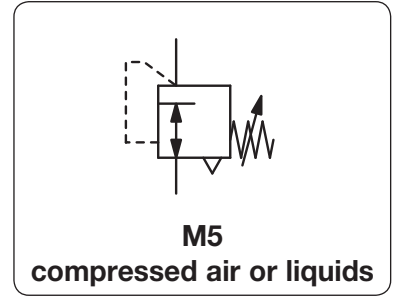

Dimensions			Flow rate	Supply pressure	Connection	Pressure range	Order number
A	B	A/F	l/min*1	max. bar	thread	bar	
mm	mm	mm			M5		

Pressure regulator for air				supply pressure max. 6 / 10 bar, relieving	RR-M5
19	40	17	70	6	RR-M5A
17	40	17	70	10	RR-M5C



RR-M5

Pressure regulator for water				supply pressure max. 6 / 10 bar, non-relieving	RR-M5
19	40	17	1.2	6	RR-M5AK
17	40	17	1.2	10	RR-M5CK



RR-M5

Special options, add the appropriate letter

for oxygen specially cleaned, with oxygen grease minimum purchase 50 pieces RR-M5 . . K15

Accessories

plastic panel nut

M12x1K

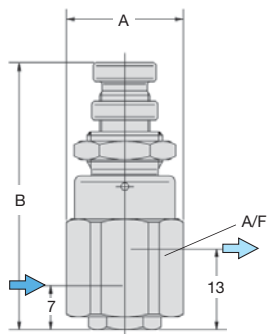
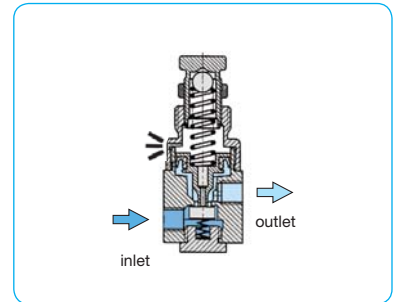

RR-M5

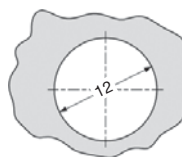

panel cut-out

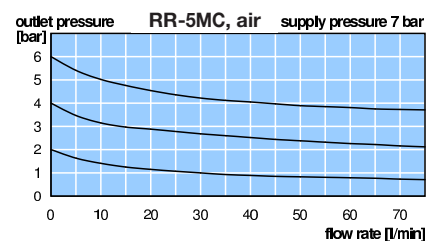

*1 for compressed air: 7 bar supply pressure and 6 bar outlet pressure and 2 bar pressure drop for water: supply pressure 2 bar above outlet pressure

PDF CAD
www.aircom.net



Order example:
RR-M5A

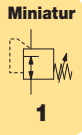

Description	Piston-operated compact pressure regulator with special seals for applications in the chemical and medical industry. Mounting nut included.
Media	compressed air, non-corrosive gases or liquids
Supply pressure	max. 21 bar
Adjustment	by knurled-head screw
Relieving function	relieving or non-relieving
Gauge port	not available
Mounting position	any
Temperature range	0 °C to 80 °C / 32 °F to 176 °F for NBR/Buna-N 0 °C to 110 °C / 32 °F to 230 °F for EPDM for appropriately conditioned compressed air down to -30°C / -22°F
Material	Body: brass Elastomer: NBR/Buna-N, optionally FKM or EPDM Inner valve: stainless steel and brass

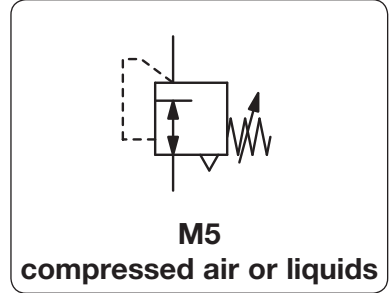

Dimensions			Description	Flow rate	Connection thread		Pressure range	Order number
A	B	A/F			Inlet	Outlet		
mm	mm	mm		l/min*1	M5 / NPT	M5 / 10-32"	bar	

Regulator with male thread				supply pressure max. 21 bar				MAR-1P	
18	71	9.5	relieving	120	1/8" NPTa	10-32"	0.2 ... 1.4	MAR-1P-20	
							0.2 ... 3.5	MAR-1P-50	
							0.2 ... 7.0	MAR-1P	
18	71	9.5	non-relieving	120	1/8" NPTa	M5	0.2 ... 1.4	MAR-1PNR-20	
							0.2 ... 3.5	MAR-1PNR-50	
							0.2 ... 7.0	MAR-1PNR	



MAR-1P, with male thread

Regulator with female thread				supply pressure max. 21 bar				MAR-1	
18	65	9.5	relieving	120	M5	M5	0.2 ... 1.4	MAR-1-20	
							0.2 ... 3.5	MAR-1-50	
							0.2 ... 7.0	MAR-1	
18	65	9.5	non-relieving	120	M5	M5	0.2 ... 1.4	MAR-1NR-20	
							0.2 ... 3.5	MAR-1NR-50	
							0.2 ... 7.0	MAR-1NR	



MAR-1, with female thread

Special options, add the appropriate letter

for oxygen	specialy cleaned, with oxygen grease	MAR-...-...15
FKM elastomer		MAR-...-...V
EPDM elastomer		MAR-...-...E
chemically nickel-plated	throughout	MAR-...-...X13

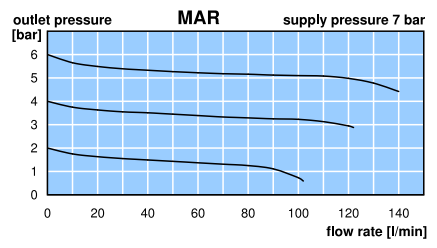
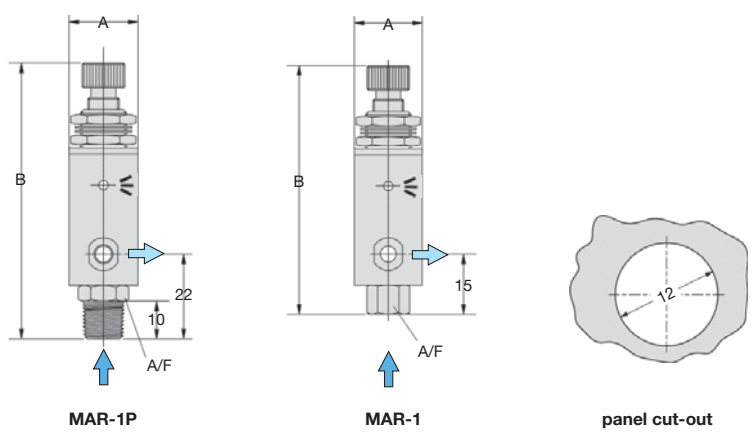

*1 at 7 bar supply pressure, 6 bar outlet pressure and 1 bar pressure drop

Plastic Miniature Precision Pressure Regulator

R800 / R900



Description	Miniature precision regulator with high supply sensitivity, small dimension, light weight. Hysteresis-free adjustment up to 20 turns. compressed air or non-corrosive gases max. 10 bar	
Media	compressed air or non-corrosive gases	
Supply pressure Accuracy	R800 / R900 / R901	R810 / R910 / R911
	at supply pressure variation of 1 bar: < 7 mbar pressure deviation	< 20 mbar pressure deviation
	at supply pressure removal/reapplication: < 7 mbar pressure deviation	< 17 mbar pressure deviation
	setting accuracy: < 2.5 mbar	< 5 mbar
Air consumption	0.35 l/min at 7 bar supply	0 l/min, flow > 20 ml/min recommended
Relieving function	relieving, optionally non-relieving	
Relief capacity	15 l/min at 0.35 bar outlet above set-point	
Temperature range	4 °C to 66 °C / 40 °F to 150 °F	
Material	Body: polysulfones Elastomer: NBR/Buna-N Inner valve: stainless steel and acetal	
	Gauge port	not available

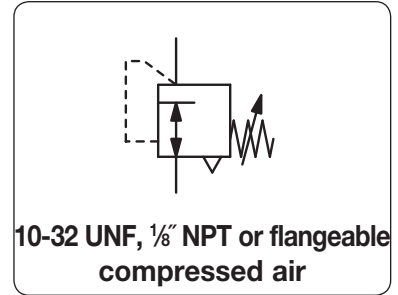

Dimensions			Pressure adjustment	Flow rate	Pressure range	Order number for manifold with o-ring	Order number 10-32 UNF standard
A	B	C	by	l/min*1	bar		
mm	mm	mm					

Precision pressure regulator						supply pressure max. 10 bar, relieving, with constant bleed	R900
29	78	8	knob	65	0.03 ... 0.24	R900-3,5MWK	R900-3,5WK
					0.03 ... 0.7	R900- 10MWK	R900- 10WK
					0.03 ... 2.1	R900- 30MWK	R900- 30WK
					0.03 ... 4.2	R900- 60MWK	R900- 60WK
					0.03 ... 6.2	R900- 90MWK	R900- 90WK
29	60	8	spindle	65	0.03 ... 0.24	R900-3,5WOS	R900-3,5WOS
					0.03 ... 0.7	R900- 10WOS	R900- 10WOS
					0.03 ... 2.1	R900- 30WOS	R900- 30WOS
					0.03 ... 4.2	R900- 60WOS	R900- 60WOS
					0.03 ... 6.2	R900- 90WOS	R900- 90WOS
29	43	8	preset	65	to be indicated	R901- .. M	R901- ..



Special options, add the appropriate letter

1/8" NPT	connection thread, width 40 mm	R8...W...
non-relieving	without constant bleed	R.1-.....
for oxygen	specially cleaned	R.....15



Accessories

mounting bracket made of steel for R800 and R900 BW15-01

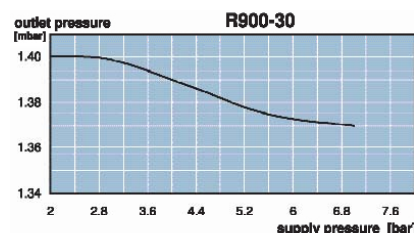
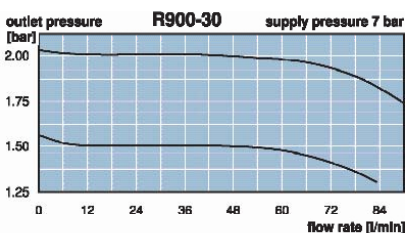
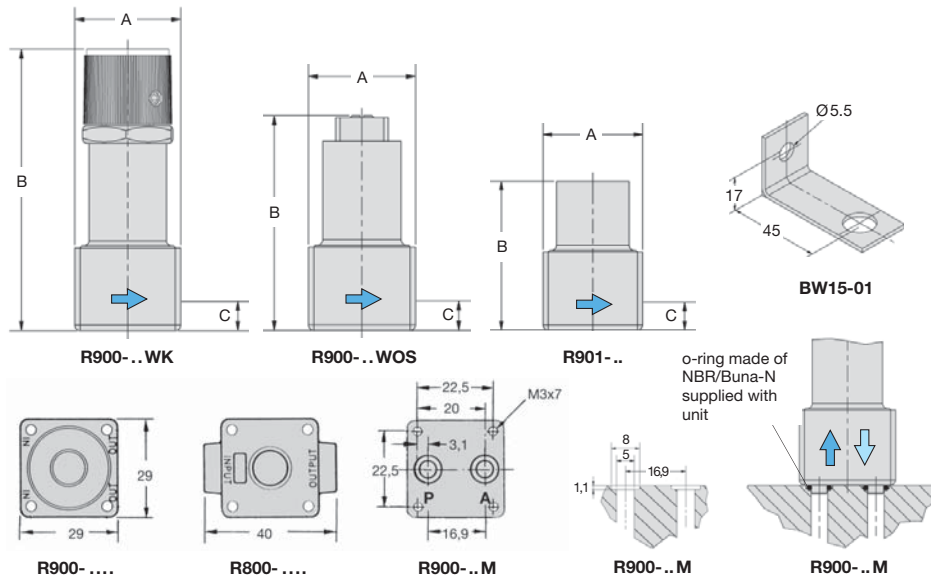

*1 at 7 bar supply pressure and max. outlet pressure

PDF CAD
www.aircom.net

Order example:
R900-3,5MWK

Miniature Precision Pressure Regulator

RT

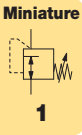

Description	Compact, high-precision, diaphragm-operated pressure regulator for panel-mounting.	
Media	non-corrosive gases, filtered, lubricated or unlubricated compressed air	
Supply pressure	max. 17 bar	
Air consumption	ca 1.5 l/min at 7 bar supply pressure	
Adjustment	by handwheel with locknut	
Relieving function	relieving	
Gauge port	RT-M5: gauge port M5	RT-MF: not available
Mounting position:	any	
Temperature range	0 °C to 70 °C / 32 °F to 158 °F, for appropriately conditioned compressed air down to -30 °C / -22 °F	
Material	Body: anodized aluminium Elastomer: FKM Inner valve: stainless steel and brass	

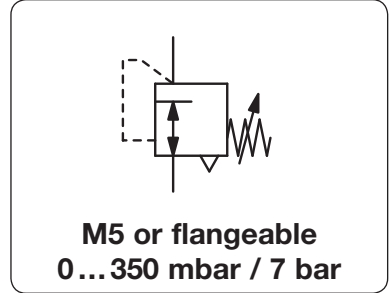

Dimensions			Flow rate	Supply pressure	Connection	Pressure range	Order number
A	B	C	l/min*1	max. bar	thread	bar	
mm	mm	mm			M5 / Flansch		

Pressure regulator M5				supply pressure max. 17 bar, with constant bleed		RT	
25	83	14.5	100	17	M5	0... 0.35	RT-M5A
						0... 1.1	RT-M5B
						0... 2.1	RT-M5C
						0... 4.2	RT-M5D
						0... 7.0	RT-M5E



**RT-M5C
with mounting nut**

Regulator with flange				supply pressure max. 17 bar, with constant bleed		RT	
25	83	-	100	17	flange	0... 0.35	RT-MFA
						0... 1.1	RT-MFB
						0... 2.1	RT-MFC
						0... 4.2	RT-MFD
						0... 7.0	RT-MFE



**RT-MFC
with flange and mounting nut**

Special options, add the appropriate letter		
side connection	M5 or o-ring	RT-M. .X14
1/16" NPT	ports with female threads	RT-M. .X61

Accessories

mounting bracket made of steel, mounting nut at the device **BW10-01**

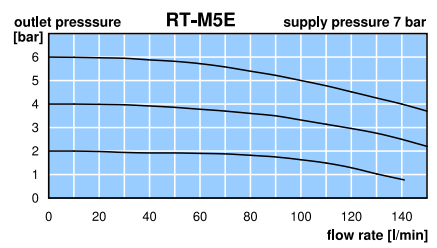
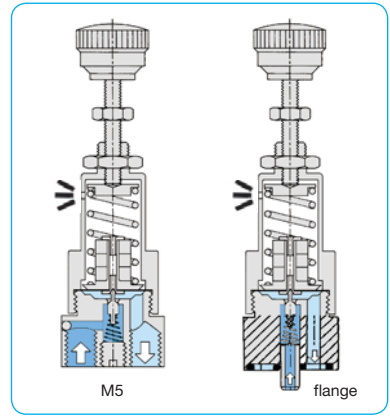
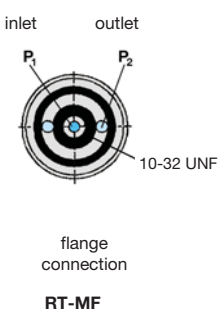
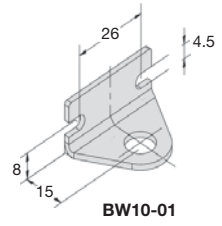
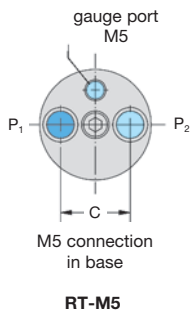
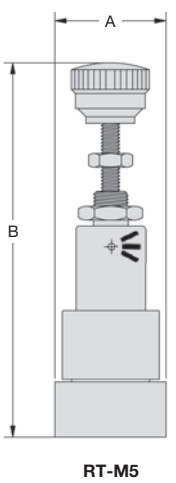

*1 for compressed air: 7 bar supply pressure, 6 bar outlet pressure and 1 bar pressure drop

PDF CAD
www.aircom.net

**Order example:
RT-M5A**

Description	Diaphragm miniature pressure regulator of small and lightweight design. The regulator has increased accuracy due to a rolling diaphragm and a piston compensated to inlet pressure.	
Media	compressed air, non-corrosive gases or liquids	
Supply pressure	max. 16 bar	
Air consumption	without constant bleed	R039-F with max. 3 l/min air consumption
Adjustment	by plastic knob with snap-lock	
Relieving function	relieving for compressed air, non-relieving for liquids,	red adjusting knob black adjusting knob
Gauge port	G $\frac{1}{8}$ on both sides of the body, screw plugs supplied	
Mounting position	any	
Temperature range	0 °C to 50 °C / 32 °F to 122 °F for NBR/Buna-N	
Material	Body: POM with brass thread insert Elastomer: NBR/Buna-N Inner valve: brass	

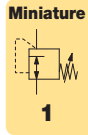
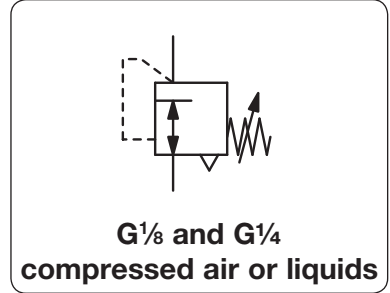

Dimensions			Flow rate		Connection	Pressure	Order number	Order number
A	B	C	water	air	thread	range	for water	for compressed air
mm	mm	mm	l/min*1	l/min*1	G	bar	non-relieving	relieving

Regulator w. increased accuracy							supply pressure max. 16 bar, w. rolling diaphragm, inlet pressure-compensated			R039
41	86	11	5	350	G $\frac{1}{8}$	0.1 ... 1	R039-010K	R039-010		
						0.2 ... 2	R039-01AK	R039-01A		
						0.2 ... 4	R039-01BK	R039-01B		
						0.3 ... 8	R039-01CK	R039-01C		
						0.3 ... 12	R039-01DK	R039-01D		
41	86	11	5	380	G $\frac{1}{4}$	0.1 ... 1	R039-020K	R039-020		
						0.2 ... 2	R039-02AK	R039-02A		
						0.2 ... 4	R039-02BK	R039-02B		
						0.3 ... 8	R039-02CK	R039-02C		
						0.3 ... 12	R039-02DK	R039-02D		



R039

Precision pressure regulator							3 l/min air consumption, P _i : max. 16 bar, w. rolling diaphragm, inlet pressure-compensated			R039-F
41	86	11	5	350	G $\frac{1}{8}$	0.1 ... 1	R039-010KF	R039-010F		
						0.2 ... 2	R039-01AKF	R039-01AF		
						0.2 ... 4	R039-01BKF	R039-01BF		
						0.3 ... 8	R039-01CKF	R039-01CF		
						0.3 ... 12	R039-01DKF	R039-01DF		
41	86	11	5	380	G $\frac{1}{4}$	0.1 ... 1	R039-020KF	R039-020F		
						0.2 ... 2	R039-02AKF	R039-02AF		
						0.2 ... 4	R039-02BKF	R039-02BF		
						0.3 ... 8	R039-02CKF	R039-02CF		
						0.3 ... 12	R039-02DKF	R039-02DF		



R039-K

Special options, add the appropriate letter			
adjustment lock	non-adjustable knob		R039-0..T
without gauge port			R039-0..X02
for oxygen	specialy cleaned, with oxygen grease	not for R039-0..F	R039-0..K15

Accessories

pressure gauge	Ø 40 mm, 0...*2 bar, G $\frac{1}{8}$	MA4001-...*2
mounting bracket	made of steel	BW30-02
mounting nut	made of plastic	M30x1,5K
	made of aluminium	M30x1,5A

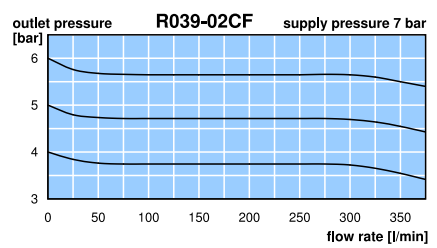
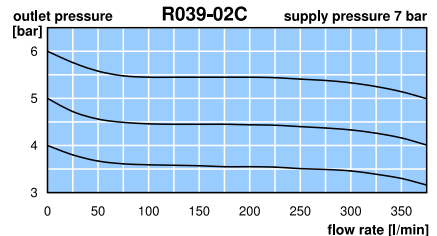
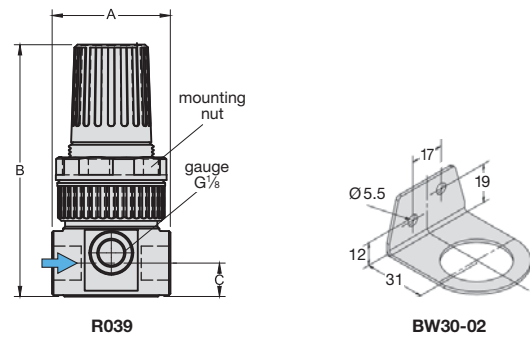

*1 at 7 bar supply pressure, 6 bar outlet pressure and 1 bar pressure drop, for water: supply pressure 2 bar above outlet pressure
*2 02 = 0...2.5 bar, 04 = 0...4 bar, 10 = 0...10 bar, 16 = 0...16 bar

Modular Miniature Pressure Regulator „AirLogic“ R6 / RP / M5000

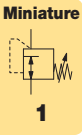

Description

Pressure regulator R6 Design as R7 but for bottom-sided flange assembly via fittings and o-rings made of NBR/Buna-N. Mounting through four screws (M3) with extremely small screw heads.

Pressure regulator RP This model guards against unauthorised tampering of pressure. Alternatively available with preset pressure. The pressure is to be set between 30 mbar and 2.8 bar. Its headroom is reduced to 49 mm.

Diverter block M5000 M3000 features four ports sideways and one on top. All ports can be provided with threads or blank slides, the ports sideways optionally with connector slides.

Top cover

Connector slide

Assembly After loosening the bottom screw any placements of threads, connector and blank slides are possible. Sealing results from o-rings made of NBR/Buna-N.

Temperature range 4 °C to 70 °C / 39.2 °F to 158 °F

Material Body: glass fiber-reinforced Celcon Inner valve: stainless steel and Celcon
Elastomer: NBR/Buna-N

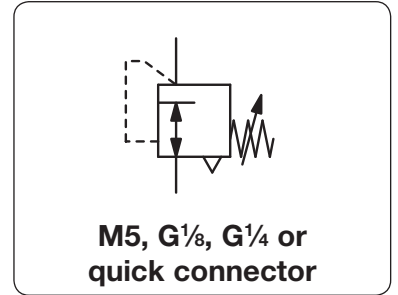

Dimensions			Flow rate l/min*1	Supply pressure max. bar	Connection thread G/ flange	Pressure range bar	Order number
A	B	C					
mm	mm	mm					

Precision regulator with flange					with adjusting knob, relieving, gauge port G $\frac{1}{8}$ on one side	R6	
47	92	-	140	10	flange	0.01 ... 0.7 0.02 ... 2.1 0.03 ... 4.1 0.03 ... 7.0	R6-010-B1BB R6-030-B1BB R6-060-B1BB R6-100-B1BB



Regulator with adjustment lock					adjustment with socket wrench, relieving, gauge port G $\frac{1}{8}$ on one side	RP	
47	49	14	140	10	G $\frac{1}{8}$	0.03 ... 2.8 *2	RP7-040-111B
32	49	-			flange	0.03 ... 2.8 *2	RP6-040-B1BB



Diverter block G $\frac{1}{8}$				e.g. all ports G $\frac{1}{8}$	M5000		
47	42	14	without filter	-	G $\frac{1}{8}$	-	M5000-11111
			with filter, 380 μ m		connection		M5001-11111

Special options and accessories

see adjoining page

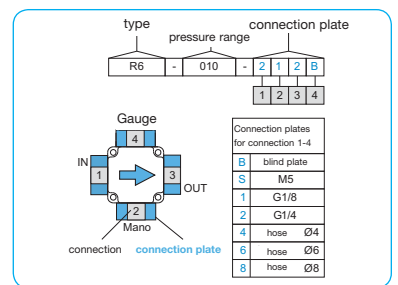
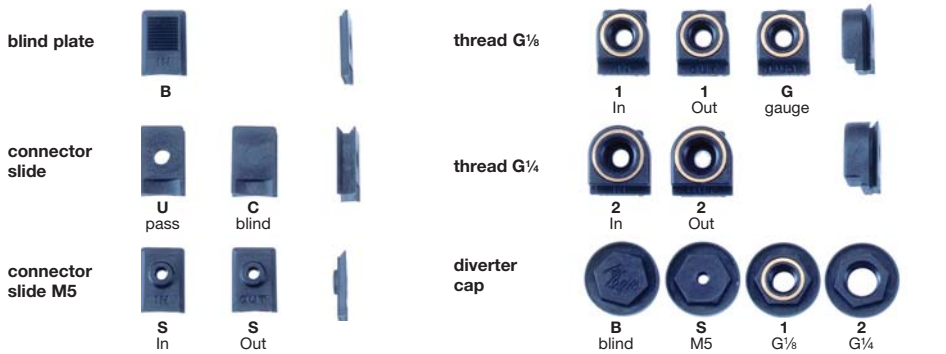
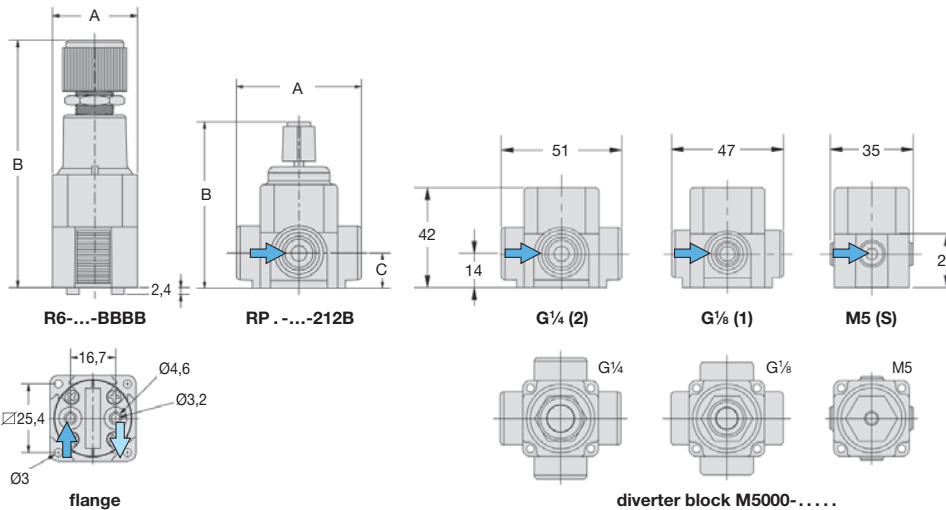

*1 at 7 bar supply pressure, 6 bar outlet pressure and 1 bar pressure drop

*2 indicate preset pressure on order

PDF CAD
www.aircom.net



Order example:
R6-010-B1BB

Description	Miniature pressure regulator with unique modular dovetail design allowing its individual use or assembly into a modular combination of pneumatic components through connector slides.	
Identification marking	The item no. includes a four-digit number starting with the input port and continuing counterclockwise. The digit corresponds with the type of connector slide, e.g. 1 for G $\frac{1}{8}$, 2 for G $\frac{1}{4}$ or B for blank.	
Pressure regulator R7	Designed for precise regulation of pressure. The regulator possesses a 20 turn adjustment range and excellent repeatability. The valve seat is protected by a filter/strainer at the input port.	
Media	5 μ m filtered compressed air and non-corrosive gases	Supply pressure max. 10 bar
Accuracy	at supply pressure variation of 1 bar: at supply pressure removal/reapplication: at variations in temperature of 25 °C / K:	< 10 mbar pressure deviation < 10 mbar pressure deviation < 10 mbar pressure deviation
Air consumption	0.3 l/min at 7 bar supply pressure	Adjustment by knob
Relieving function	relieving	Mounting position any
Gauge port	G $\frac{1}{8}$ via threaded slide	

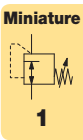
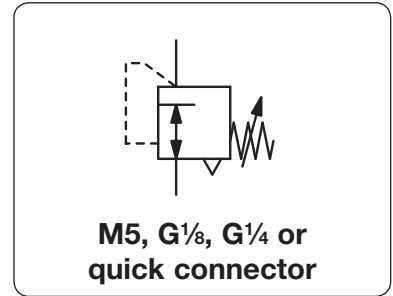

Dimensions			Flow rate	Supply pressure	Connection thread	Pressure rang	Order number
A	B	C					
mm	mm	mm	l/min*1	max. bar	G	bar	

Precision regulator				with adjusting knob, relieving, gauge port G $\frac{1}{8}$ on one side		R7	
47	92	14	140	10	G $\frac{1}{8}$	0.01 ... 0.7 0.02 ... 2.1 0.03 ... 4.1 0.03 ... 7.0	R7-010-111B R7-030-111B R7-060-111B R7-100-111B
51	92	14	140	10	G $\frac{1}{4}$	0.01 ... 0.7 0.02 ... 2.1 0.03 ... 4.1 0.03 ... 7.0	R7-010-212B R7-030-212B R7-060-212B R7-100-212B



Special options, add the appropriate letter or number

with spindle thread	M5 G $\frac{1}{8}$ G $\frac{1}{4}$	screwdriver adjustment, height 77 mm connection thread	R-...-... S R-...-S ... R-...-1 ... R-...-2 ... R-...-4 ... R-...-6 ... R-...-8 ... R-...-B ... R-...-U ... R-...-C ... R-...-W ...
quick connector	\varnothing 4 \varnothing 6 \varnothing 8	external diameter of hose	
breach plate connection plate		with permanent pressure supply without passage, modular combination of two devices	
wall mounting		at breach plate	



Accessories

pressure gauge	\varnothing 23 mm, 0...*2 bar, G $\frac{1}{8}$	MA2301-...*2
-----------------------	--	--------------

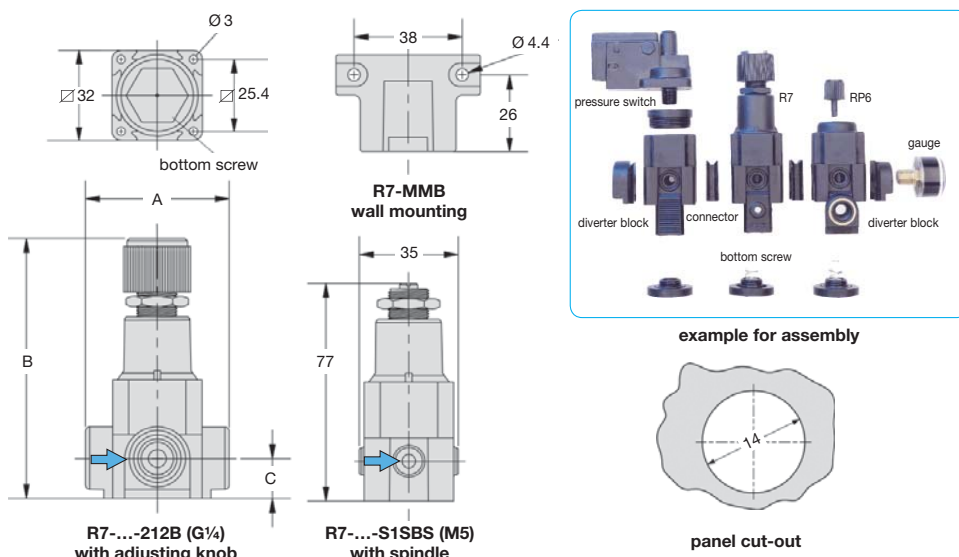

*1 at 7 bar supply pressure, 6 bar outlet pressure and 1 bar pressure drop
*2 04 = 0...4 bar, 06 = 0...6 bar, 10 = 0...10 bar

Precision Regulator with Inlet Pressure Compensation R342 / R344

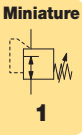

Description	Compact diaphragm regulator for quick regulating operations. Due to the pressure-compensated piston fluctuations on inlet pressure have only marginal effect on the outlet pressure's stability.
Media	compressed air or non-corrosive gases
Supply pressure	max. 17 bar
Adjustment	by plastic knob with snap-lock
Relieving function	relieving, optionally non-relieving
Gauge port	G $\frac{1}{8}$ on both sides of the body, screw plugs supplied. Without gauge port at regulator with flange.
Mounting position	any
Temperature range	0 °C to 70 °C / 32 °F to 158 °F, for appropriately conditioned compressed air down to -30 °C / -22 °F
Material	Body: aluminium Spring cage: glass fibre-reinforced plastic Elastomer: NBR/Buna-N Inner valve: steel, brass, plastic Valve seat: acetal

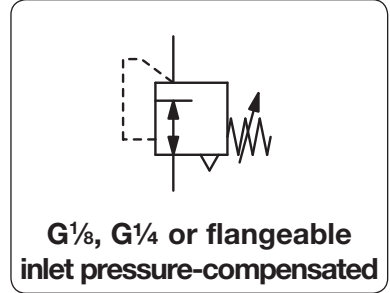

Dimensions			Flow rate l/min	Connection thread G / flange	Pressure range bar	Order number
A	B	C				

Regulator w. inlet pressure compensation						supply pressure max. 17 bar, relieving, without constant bleed	R344
40	83	14	500	G $\frac{1}{8}$	0.2...2		R344-01A
					0.2...4		R344-01B
					0.3...9		R344-01C
40	83	14	500	G $\frac{1}{4}$	0.2...2		R344-02A
					0.2...4		R344-02B
					0.3...9		R344-02C



R344

Regulator with flange						supply pressure max. 17 bar, relieving, without constant bleed, inlet pressure compensation	R342
38	83	13	500	flange	0.2...2		R342-0MA
					0.2...4		R342-0MB
					0.3...9		R342-0MC



R342, flangeable

Special options, add the appropriate letter or number		
NPT	connection thread	R344-0 . . N
non-relieving for oxygen	without relieving function	R34.-0 . . K
	specially cleaned, with oxygen grease	R34.-0 . . K15
FKM elastomer		R34.-0 . . X64

Accessories			
pressure gauge	Ø 40 mm, 0... ^{*2} bar, G $\frac{1}{8}$	R344 only	MA4001-...^{*2}
mounting bracket	made of steel	R344 only	BW30-02
mounting nut	made of plastic	R344 only	M30x1,5K
	made of aluminium	R344 only	M30x1,5A

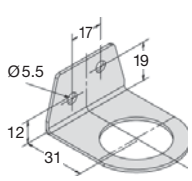

BW30-02

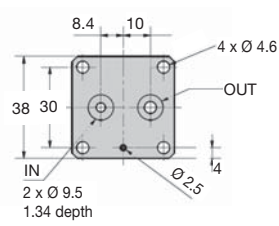

R342 bottom view

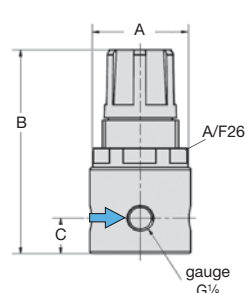

R344

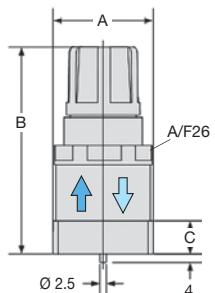

R342

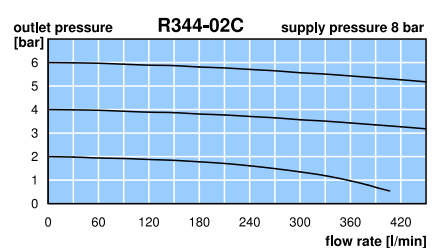

*1 at 8 bar supply pressure, 6 bar outlet pressure and 1 bar pressure drop *2 02 = 0...2.5 bar, 04 = 0...4 bar, 10 = 0...10

Description	Compact regulator with diaphragm.
Media	compressed air, non-corrosive gases or liquids
Supply pressure	max. 21 bar
Adjustment	by plastic knob with snap-lock
Relieving function	relieving, optionally non-relieving
Gauge port	G $\frac{1}{8}$ on both sides of the body, screw plugs supplied
Mounting position	any
Temperature range	0 °C to 50 °C / 32 °F to 122 °F, for appropriately conditioned compressed air down to -30 °C / -22 °F 0 °C to 80 °C / 32 °F to 176 °F, for spring cage made of brass
Material	Body: brass at R364, aluminium at R374 Spring cage: glass fibre reinforced plastic, optionally brass Elastomer: NBR/Buna-N, optionally FKM Inner valve: brass, optionally stainless steel

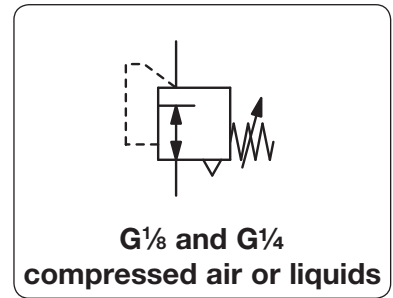

Dimensions			Flow rate		Connection	Pressure	Order
A	B	C	m ³ /h*1	l/min*1	thread	range	number
mm	mm	mm			G	bar	

Brass pressure regulator					supply pressure max. 21 bar, relieving	R364
35	76	12	27	450	G $\frac{1}{8}$	R364-010 R364-01A R364-01B R364-01C R364-01D
35	76	12	27	450	G $\frac{1}{4}$	R364-020 R364-02A R364-02B R364-02C R364-02D



R364
made of brass

Aluminium pressure regulator					supply pressure max. 21 bar, relieving	R374
35	76	12	27	450	G $\frac{1}{8}$	R374-010 R374-01A R374-01B R374-01C R374-01D
35	76	12	27	450	G $\frac{1}{4}$	R374-020 R374-02A R374-02B R374-02C R374-02D



R374
made of aluminium

Special options, add the appropriate letter

NPT	connection thread	R3.4-0...N
non-relieving	without relieving function	R3.4-0...K
adjustment lock	socket wrench adjustment, height 64 mm	R3.4-0...T
free of grease and oil	especially cleaned, suitable for oxygen	R3.4-0...L
FKM elastomer	inner parts made of brass	R3.4-0...X64
	inner parts made of brass	R3.4-0...X08
EPDM elastomer	inner parts m. o. brass, PTFE-diaphragm, W270, KTW, DVGN approval	R364-01...X37
brass spring cage	including brass adjusting screw, max. 80 °C / 176 °F	R3.4-0...X82

Accessories

pressure gauge	Ø 40 mm, 0... ^{*2} bar, G $\frac{1}{8}$	MA4001-...^{*2}
mounting bracket	made of steel	BW30-02
mounting nut	made of plastic	M30x1,5K
	made of aluminium	M30x1,5A



R364-02CT with adjustment lock R364-02CX82 brass throughout

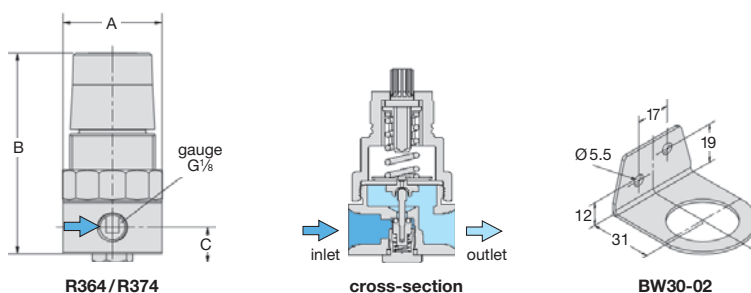

R364/R374

cross-section

BW30-02

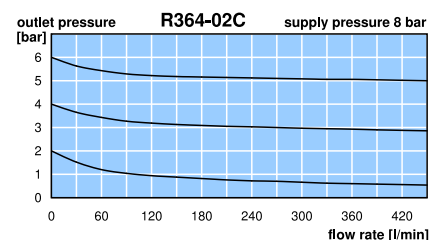

*1 at 8 bar supply pressure, 6 bar outlet pressure and 1 bar pressure drop
*2 01 = 0...1 bar, 02 = 0...2,5 bar, 04 = 0...4 bar, 10 = 0...10 bar, 16 = 0...16 bar

Gauges: see chapter for measuring devices

PDF CAD
www.aircom.net

Order example:
R364-010

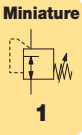

Description	R310: Diaphragm pressure regulator made of brass without constant bleed. R309: Precision pressure regulator with highly accurate inner valve and sensitive convoluted diaphragm. Of proven reliability and durability and designed for precise pressure regulation in the event of disturbances in flow, supply pressure or temperature. With very high capacity relief valve.	
Media	compressed air, non-corrosive gases or liquids	
Supply pressure	max. 25 bar for R310, max. 14 bar for R309 and R310-15	
Adjustment	by plastic knob with snap-lock	
Relieving function	relieving, optionally non-relieving for R310	
Gauge port	R310: G $\frac{1}{8}$ on both sides of the body, one screw plug supplied	R309: not available
Mounting position	any	
Temperature range	0 °C to 60 °C / 32 °F to 140 °F for NBR / Buna-N 0 °C to 80 °C / 32 °F to 176 °F for FKM or EPDM for appropriately conditioned compressed air down to -30 °C / -22 °F	
Material	Body: brass Spring cage: POM	Elastomer: NBR/Buna-N, optionally FKM or EPDM, e.g. for brake fluid Inner valve: stainless steel and brass

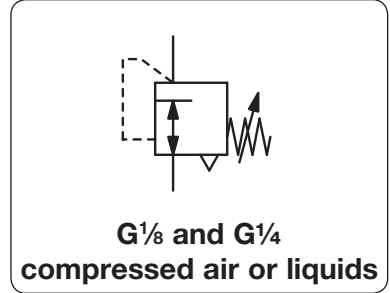

Dimensions			Flow rate	Supply pressure	Connection	Pressure range	Order number
A	B	C	l/min*1	max. bar	thread	bar	
mm	mm	mm			G		

Pressure regulator							supply pressure max. 25 bar, relieving, gauge port G $\frac{1}{8}$, inlet pressure-compensated	R310
40	80	16.5	220	25	G $\frac{1}{8}$	0.1... 3	R310-01B	
						0.4... 10	R310-01D	
						0.5... 16	R310-01E	
40	80	16.5	220	25	G $\frac{1}{4}$	0.1... 3	R310-02B	
						0.4... 10	R310-02D	
						0.5... 16	R310-02E	

Precision press. regulator							P1: max. 14 bar, relieving, inlet pressure-compensated without constant bleed, suitable for oxygen	R309
36	77	15	220	14	G $\frac{1}{8}$	0.1... 3	R309-01B	
						0.4... 6	R309-01C	



R310

Wahlweise Ausführung, es ist der entsprechende Buchstabe hinzuzufügen

non-relieving	without relieving function	R310-0...K
for oxygen	specially cleaned, P ₁ : max. 14 bar, P ₂ : max. 10 bar	R310-0...K15
FKM elastomer		R310-0...V
EPDM elastomer	non-relieving, e.g. for brake fluid	R310-0...KE



R309
accessory: mounting nut

Accessories

pressure gauge	Ø 40 mm, 0...*2 bar, G $\frac{1}{8}$	R310 only	MA4001-...*2
mounting bracket	made of steel		BW30-02
mounting nut	made of plastic made of brass		M30x1,5K M30x1,5M

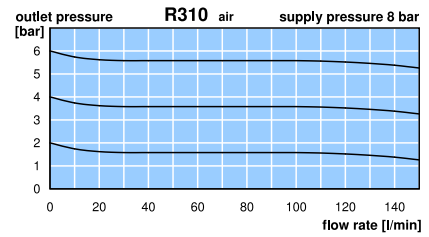
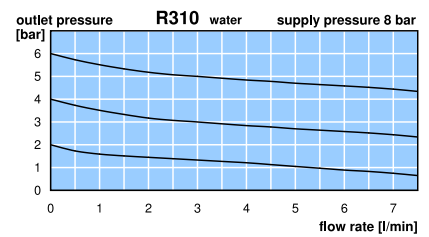
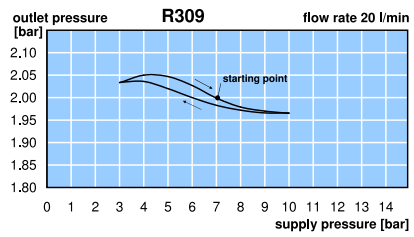
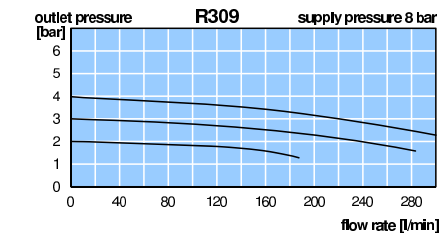
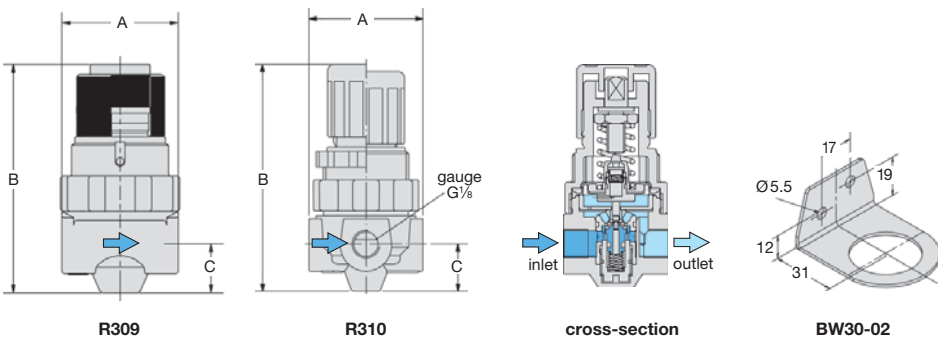

*1 for compressed air: 8 bar supply pressure, 4 bar outlet pressure and 1 bar pressure drop
*2 01 = 0...1 bar, 04 = 0...4 bar, 10 = 0...10 bar, 16 = 0...16 bar

Miniature Pressure Regulator with FDA Approval

R037

Description	Diaphragm miniature pressure regulator made of plastic and of small and lightweight design. All fluid-contact parts are approved by the FDA.
Application area	food industry and water circulation, e.g. for dialysis devices
Media	compressed air, non-corrosive gases, deionized water or other liquids
Supply pressure	max. 16 bar
Adjustment	by plastic knob with snap-lock
Relieving function	non-relieving
Gauge port	not available
Mounting position	any
Temperature range	0 °C to 50 °C / 32 °F to 122 °F
Material	Body: POM technopolymer with thread insert of SST 316, approved by FDA and WRAS Elastomer: EPDM with thread insert of SST 316, approved by FDA and KTW Valve and o-ring: Hytrel and EPDM, FDA-approved Grease: Klüber, UH184-201

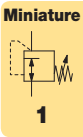
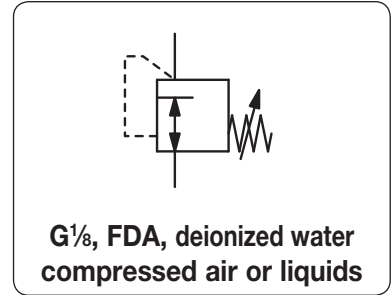

Dimensions			Flow rate		Connection	Pressure	Order
A	B	C	water	air	thread	range	number
mm	mm	mm	l/min*1	l/min	G	bar	

Pressure regulator w. FDA approval			supply pressure max. 16 bar, non-relieving EPDM, with inlet pressure compensation		R037		
41	86	11	5	350	G ¹ / ₈	0.1 ... 1	R037-010K
						0.1 ... 2	R037-01AK
						0.2 ... 4	R037-01BK
						0.3 ... 8	R037-01CK
						0.4 ... 12	R037-01DK



R037

Accessories

mounting bracket	made of steel	BW30-02
mounting nut	made of plastic	M30x1,5K
	made of aluminium	M30x1,5A

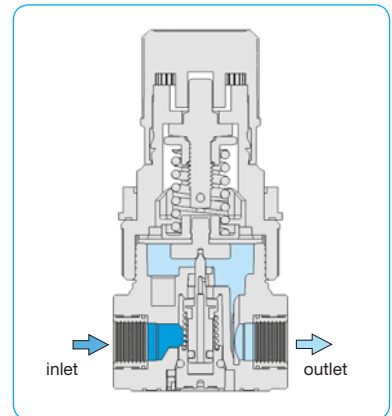

cross-section

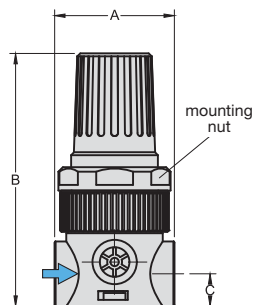

R037

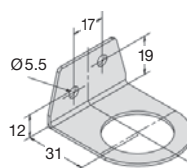

BW30-02

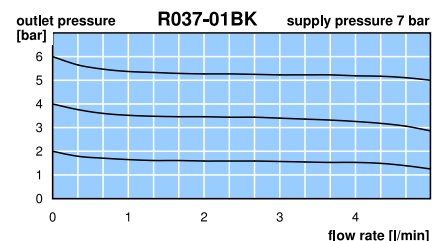

*1 supply pressure 1 bar above outlet pressure



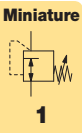

Description	Precision pressure regulator made of plastic, diaphragm-operated, with tamper-proof knob and without constant bleed. Excellent for portable systems thanks to small size and light weight of only 70 g. The regulator is suitable for oxygen and air.
Media	compressed air or non-corrosive gases
Supply pressure	max. 10 bar
Adjustment	by plastic knob with snap-lock
Relieving function	relieving, optionally non-relieving
Gauge port	G $\frac{1}{8}$ on both sides of the body, one screw plug supplied
Mounting position	any
Temperature range	0 °C to 60 °C / 32 °F to 140 °F
Material	Body: POM Elastomer: NBR/Buna-N Inner valve: brass

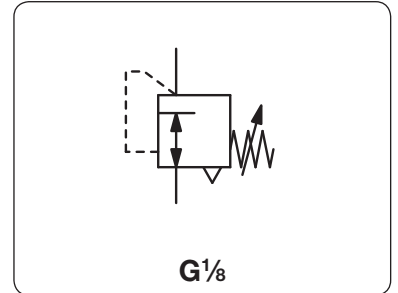

G $\frac{1}{8}$

Dimensions			Flow rate	Supply pressure	Connection thread	Pressure range	Order number
A	B	C	l/min*1	max. bar	G	bar	
mm	mm	mm					

Miniature pressure regulator	supply pressure max. 10 bar, relieving, without constant bleed	R307					
30	64	8	360	10	G $\frac{1}{8}$	0.2 ... 2.5	R307-01B
						0.2 ... 3.5	R307-01C
						0.2 ... 8.0	R307-01D

Special options, add the appropriate letter		
non-relieving	without relieving function	R307-01 . K
for oxygen	specially cleaned, with oxygen grease	R307-01 . K15



R307 accessories: gauge and mounting nut

Accessories		
pressure gauge	\varnothing 23 mm, 0...*2 bar, G $\frac{1}{8}$	MA2301-...*2
mounting nut	made of brass	M24x1,5M

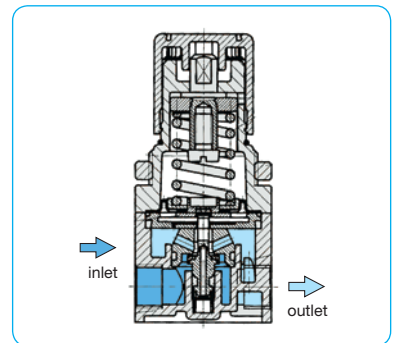

cross-section

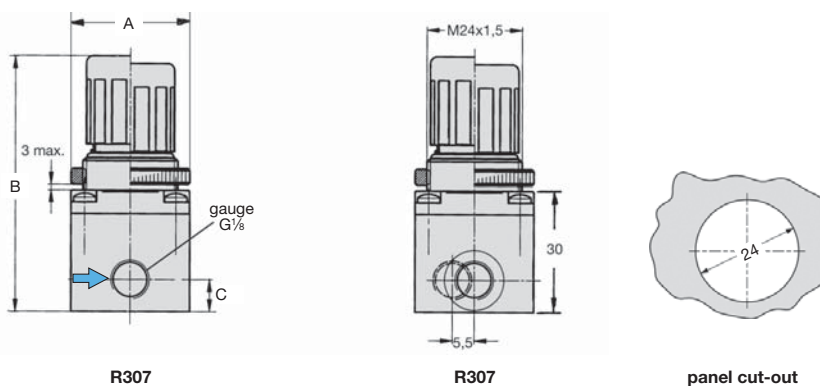

R307

R307

panel cut-out

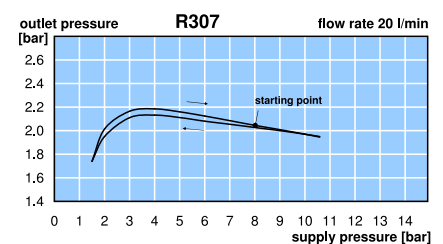
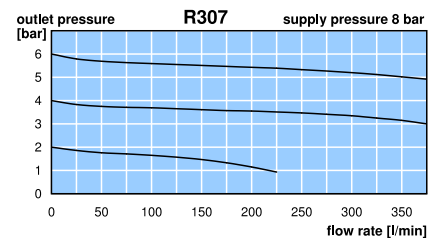

*1 at 8 bar supply pressure, 6 bar outlet pressure and 1 bar pressure drop
*2 04 = 0...4 bar, 10 = 0...10 bar

Miniature Precision Pressure Regulator \square 30 mm, with flange

R308

Description	Precision pressure regulator, made of plastic, diaphragm-operated, with tamper-proof knob and without constant bleed. Excellent for portable systems thanks to small size and light weight of only 70 g. The regulator is suitable for oxygen and air.	
Media	compressed air or non-corrosive gases	
Supply pressure	max. 10 bar	
Adjustment	by plastic knob with snap-lock	
Relieving function	relieving, optionally non-relieving	
Gauge port	not available	
Mounting position	any	
Temperature range	0° C to 60 °C / 32 °F to 140 °F	
Material	Body:	POM
	Elastomer:	NBR/Buna-N
	Inner valve:	brass

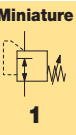
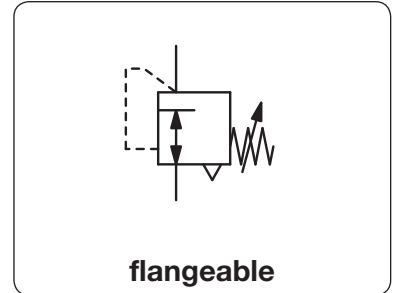

Dimensions		Flow rate	Supply pressure	Connection	Pressure range	Order number
A	B	l/min*1	max. bar	flange	bar	
mm	mm					

Precision regulator with flange				supply pressure max. 10 bar, relieving, without constant bleed	R308
30	64	200	10	flange	0 ... 0.25 R308-P00
					0.2 ... 2.5 R308-P0B
					0.2 ... 3.5 R308-P0C
					0.2 ... 8.0 R308-P0D



R308, flangeable

Special options, add the appropriate letter

non-relieving	without relieving function	R308-P0. K
or oxygen	specially cleaned, with oxygen grease	R308-P0. K15

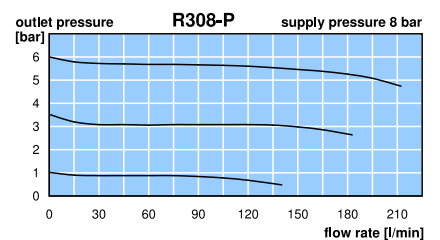
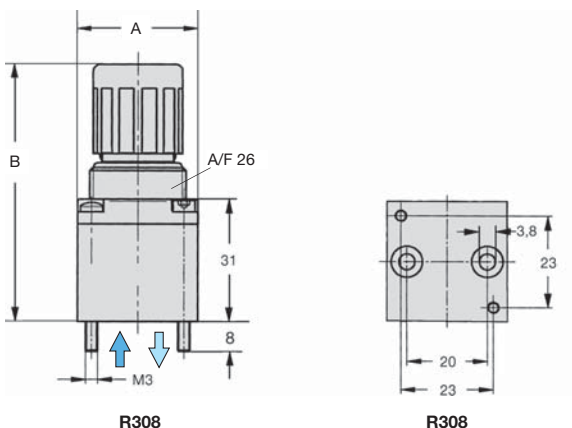
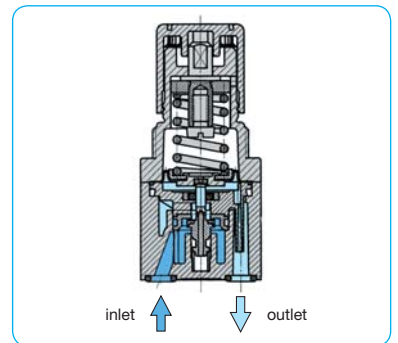

*1 for compressed air: 8 bar supply pressure, 6 bar outlet pressure and 1 bar pressure drop

Cartridge Pressure Regulator

RC

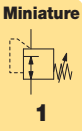

Description	Piston-operated cartridge pressure regulator suitable for assembly block.
Media	compressed air filtered to 50 µm, lubricated or unlubricated
Supply pressure	max. 10 bar
Adjustment	by knurled-head screw with locknut
Relieving function	relieving
Gauge port	not available
Mounting position	any
Temperature range	0 °C to 60 °C / 32 °F to 140 °F, for appropriately conditioned compressed air down to -30 °C / -22 °F
Material	Body: nickel-plated brass Elastomer: NBR/Buna-N

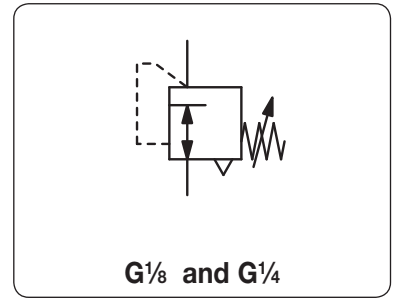

Dimensions				Flow rate	Supply pressure	Connection thread	Pressure range	Order number
A	B	C	A/F	l/min*1	max. bar	G	bar	

Cartridge regulator								supply pressure max. 10 bar, relieving, without constant bleed	RC
15	57	15	14	150	10	G ¹ / ₈	1... 8 bar		RC-01C
19	63	18	17	260	10	G ¹ / ₄	1... 8 bar		RC-02C



Step drill for cartridge seat						RCS
16	-	-	-	-	G ¹ / ₈	RCS-01
20	-	-	-	-	G ¹ / ₄	RCS-02

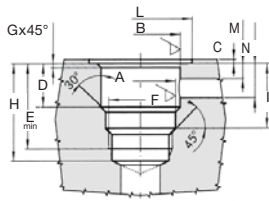

drilled hole

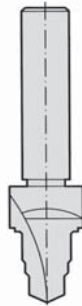

RCS

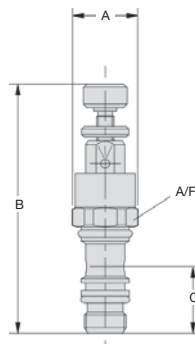

RC

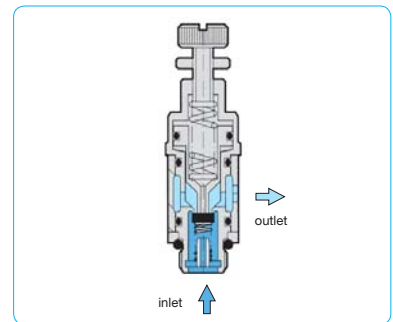

drill	F	A	B	C	D
RCS-01	1/8	9.8 - 0.1/-0	11.2 ± 0.05	0.5 ± 0.5	15.6 ± 0.07
RCS-02	1/4	13.5 + 0.1/-0	14.4 ± 0.05	0.5 ± 0.5	17.5 ± 0.07

drill	E	G	H	I	L	M	N
RCS-01	24.6	0.3	27	18.1 ± 0.2	15.4	3.5	12
RCS-02	28	0.4	31.2	20.8 ± 0.2	19.4	3.5	13.5

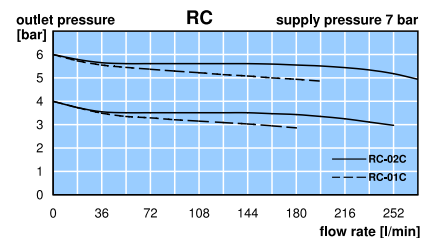

*1 at 7 bar supply pressure, 6 bar outlet pressure and 1 bar pressure drop

